

Switching 75 to 150 A at 240 to 440 VAC

- Easy-to-mount monoblock construction incorporating heat sink.
- Replaceable power cartridge.
- Incorporating operation indicator and varistor.
- A series of high-voltage (440 V) models available.



Ordering Information

Isolation	Zero cross function	Indicator	Rated output load (Applicable output load)	Rated input voltage	Model
Photocoupler	Yes	Yes	75 A at 100 to 240 VAC (75 to 264 VAC)	5 to 24 VDC 100 to 240 VAC	G3NH-2075B
			75 A at 180 to 440 VAC (150 to 484 VAC)		G3NH-4075B
			150 A at 100 to 240 VAC (75 to 264 VAC)		G3NH-2150B
			150 A at 180 to 440 VAC (150 to 484 VAC)		G3NH-4150B

Thyristor Modules are built-in. When using the G3NH to control a motor, refer to *List of Recommended Loads* on pages 3 to 5.

Replacement Parts

Name	Applicable output load	Model	Applicable Model
Thyristor Module	75 A at 75 to 264 VAC	G32A-N2075	G3NH-2075B
	75 A at 150 to 484 VAC	G32A-N4075	G3NH-4075B
	150 A at 75 to 264 VAC	G32A-N2150	G3NH-2150B
	150 A at 150 to 484 VAC	G32A-N4150	G3NH-4150B

Specifications

■ Ratings

Input

Rated voltage	Operating voltage	Impedance	Voltage level	
			Must operate voltage	Must release voltage
5 to 24 VDC	4 to 30 VDC	5 mA max.*	4 VDC max.	1 VDC min.
100 to 240 VAC	75 to 264 VAC	41 kΩ±20%	75 VAC max.	20 VAC min.

*G3NH converts the current input into a constant current.

Output

Model	Applicable load			
	Rated load voltage	Load voltage range	Load current	Inrush current
G3NH-2075B	100 to 240 VAC	75 to 264 VAC	1 to 75 A	800 A (60 Hz, 1 cycle)
G3NH-4075B	180 to 240 VAC	150 to 484 VAC		
G3NH-2150B	100 to 240 VAC	75 to 264 VAC	1 to 150 A	1,800 A (60 Hz, 1 cycle)
G3NH-4150B	180 to 440 VAC	150 to 484 VAC		

■ Characteristics

Item	G3NH-2075B	G3NH-4075B	G3NH-2150B	G3NH-4150B
Operate time	1/2 of load power source cycle + 1 ms max. (DC input) 3/2 of load power source cycle + 1 ms max. (AC input)			
Release time	1/2 of load power source cycle + 1 ms max. (DC input) 3/2 of load power source cycle + 1 ms max. (AC input)			
Output ON voltage drop	1.6 V (RMS) max.			
Leakage current	30 mA max. (at 200 VAC)	60 mA max. (at 400 VAC)	30 mA max. (at 200 VAC)	60 mA max. (at 400 VAC)
Insulation resistance	100 MΩ min. (at 500 VDC)			
Dielectric strength	2,500 VAC, 50/60 Hz for 1 min			
Vibration resistance	Malfunction: 10 to 55 Hz, 0.75-mm double amplitude			
Shock resistance	Malfunction: 500 m/s ²			
Ambient temperature	Operating: -30°C to 80°C (with no icing or condensation) Storage: -30°C to 100°C (with no icing or condensation)			
Ambient humidity	Operating: 45% to 85%			
Weight	Approx. 1.8 kg		Approx. 3.0 kg	

Engineering Data

Load Current vs. Ambient Temperature Characteristics

G3NH-□075B, G3NH-□150B

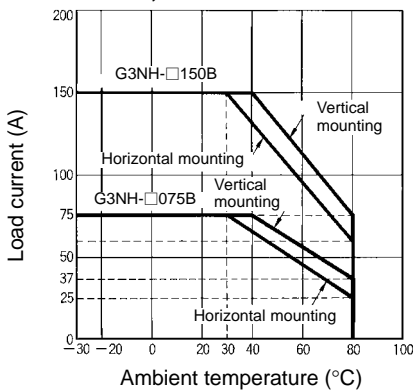

Inrush Current Resistivity

G3NH-□075B, G3NH-□150B

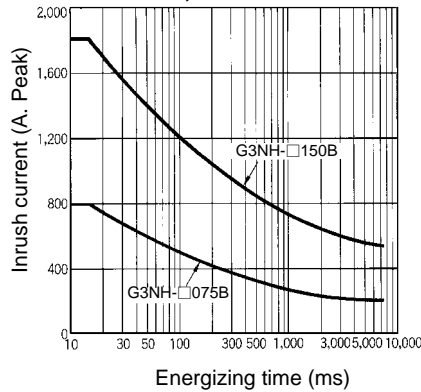

Non-repetitive
(Keep the inrush current to half the rated value if it occurs repeatedly.)

Input Current vs. Input Impedance

G3NH (4 to 30 VDC)

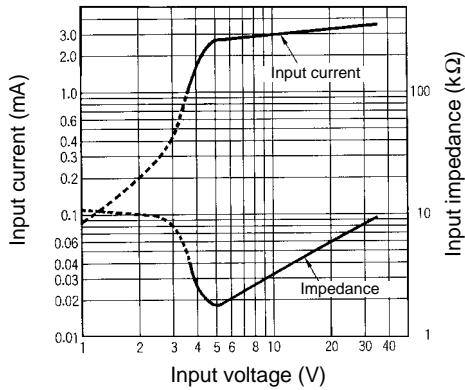

G3NH (75 to 264 VAC)

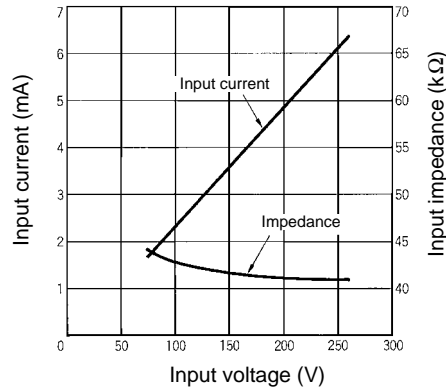

Operation

■ Replacement Parts

G32A-N Thyristor Module

The thyristor module may be damaged if the load is short-circuited, in such a case, replace the damaged thyristor module with a new one.

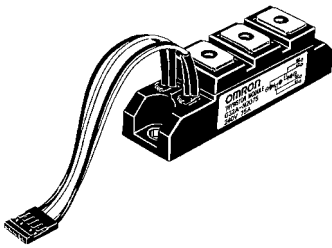

Name	Applicable load	Applicable Relay	Model
Thyristor module	75 A at 75 to 264 VAC	G3NH-2075B	G32A-N2075
	75 A at 150 to 484 VAC	G3NH-4075B	G32A-N4075
	150 A at 75 to 264 VAC	G3NH-2150B	G32A-N2150
	150 A at 150 to 484 VAC	G3NH-4150B	G32A-N4150

Replacement

Be sure to turn off the power before replacement.

1. First, remove the four screws (shown below as "A") and the transparent protective cover from the relay housing and then disconnect the wiring.
2. Remove the four screws (shown in the following as "B") and the nameplate from the relay housing.

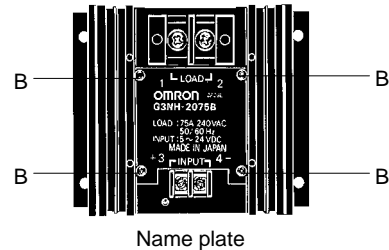
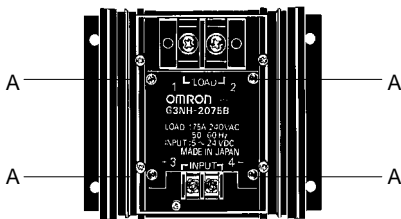

- Remove the three screws (shown in the following as "C") from inside the housing and pull the Base assy up to detach. (The Base assy cannot be removed thoroughly because of the leads connected to the base.)

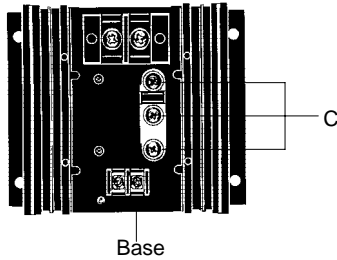

- When the Base assy is detached, you will see the leads connected to the built-in thyristor module. Pull the connector to disconnect the leads. At this point, if any defect exists in any of the electronic components on the PWB, the SSR may fail again even after the replacement of the built-in thyristor module. In such a case, consult OMRON about appropriate remedial action.

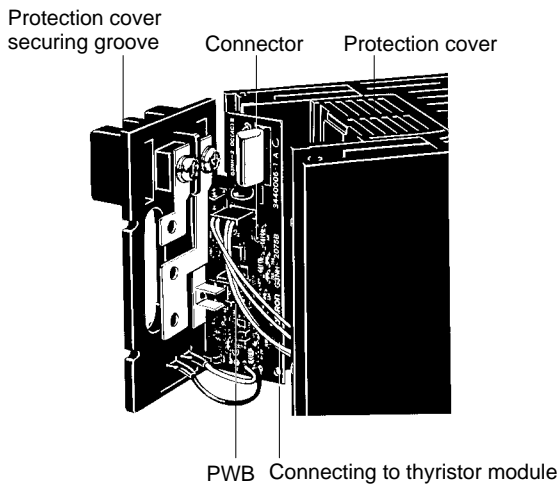

- Remove the two screws (shown in the following as "D") and take out the built-in thyristor module.

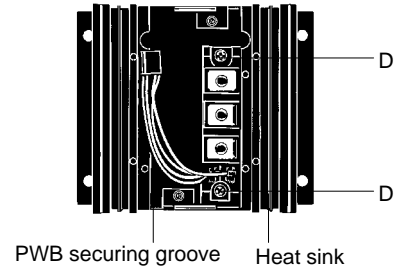

Assembly of the thyristor module must be performed in the exact reverse order of the previous disassembly steps 1 to 5.

- Before mounting the new thyristor module for replacement, wipe off the silicon grease adhering to the heat sink, keep clean the jointing surfaces of the heat sink and thyristor module, and apply the new grease (supplied as an accessory) to the jointing surfaces. Secure the thyristor module to the heat sink with the two screws "D" and tighten each screw to a torque of 2.45 to 2.94 N • m.
- Connect the thyristor module to the PWB with the socket. (The socket may be inserted in either direction.) Assemble the Base assy with the heat sink by aligning the PWB with the PWB securing groove and the protective cover with the protective cover securing groove, respectively, while exercising caution not to get any of the leads caught between the Base assy and the heat sink.
- Secure the Base assy with the three screws "C". Because a large current flows into these screw parts, make sure that any of the screws is not clogged with foreign matter and tighten each screw to a torque of 4.41 to 4.90 N • m.
- Check the assembled parts again for any lead caught between the Base assy and heat sink and for proper fitting of the PWB and protective cover into their respective securing grooves. Then, replace the nameplate and secure it with the four screws "B".
- Complete the wiring and secure the protective cover with the four screws "A".
- Apply power to the relay and check the relay for proper operation.

Dimensions

Note: All units are in millimeters unless otherwise indicated.

G3NH-2075B/4075B

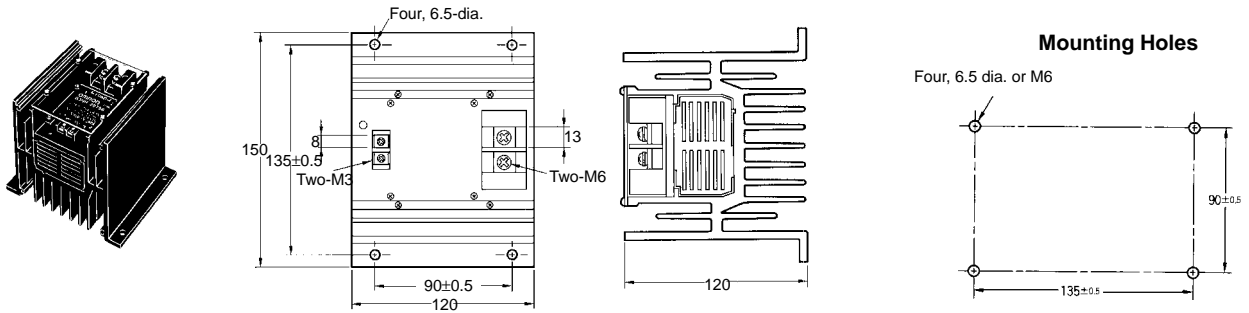

G3NH-2150B/4150B

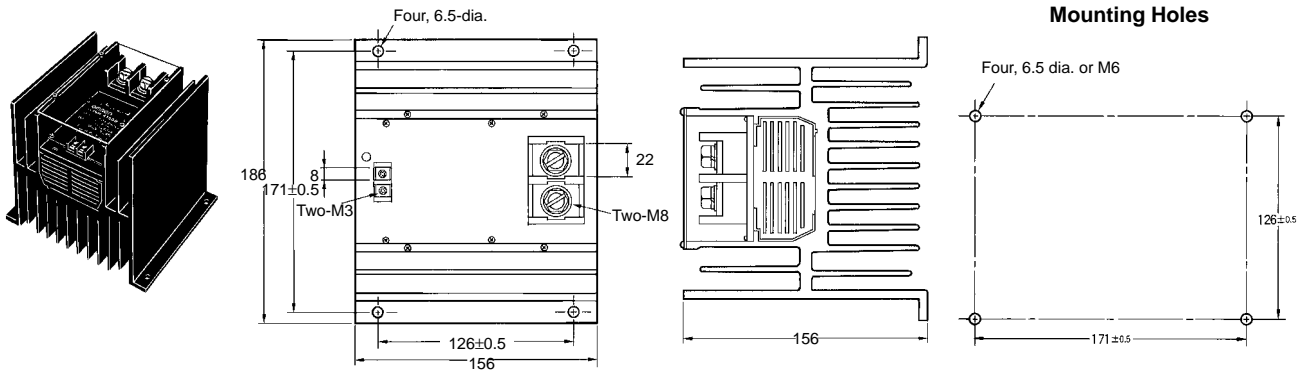

Precautions

Refer to pages 11 to 19 for general precautions.

Load Connection

Securely tighten the LOAD terminal screws with the torque specified in the following list after you connect the load to the LOAD terminals. If the tightening torque is not enough, the terminals will generate heat.

Model	Tightning torque
G3NH-□075B	4.41 to 4.90 N • m
G3NH-□150B	8.82 to 9.80 N • m

Mounting

When you locate the G3NH near other equipment, take the heat resistivity of the equipment into consideration. The temperature of the G3NH's heat sink will rise by approximately 50°C with a rated current flow through the G3NH.

The G3NH will rise the ambient temperature. When mounting the G3NH inside a panel, install a fan for proper ventilation.

When closely mounting the G3NH SSRs side by side, reduce the load current 30% lower than the specified value shown in the load current vs. ambient temperature graph.

Take proper measures so that the heat sink will be protected from dust.

ALL DIMENSIONS SHOWN ARE IN MILLIMETERS.

To convert millimeters into inches, multiply by 0.03937. To convert grams into ounces, multiply by 0.03527.